

## Maße Processklappe Serie K16 Dimensions butterfly valve series K16 DN 350 – DN 500

Baulänge: EN 558-1 Reihe 20 (DIN 3202-K1)  
 Kopfflansch: ISO 5211

Face to face dimension: EN 558-1 line 20 (DIN 3202-K1)  
 Mounting plate: ISO 5211

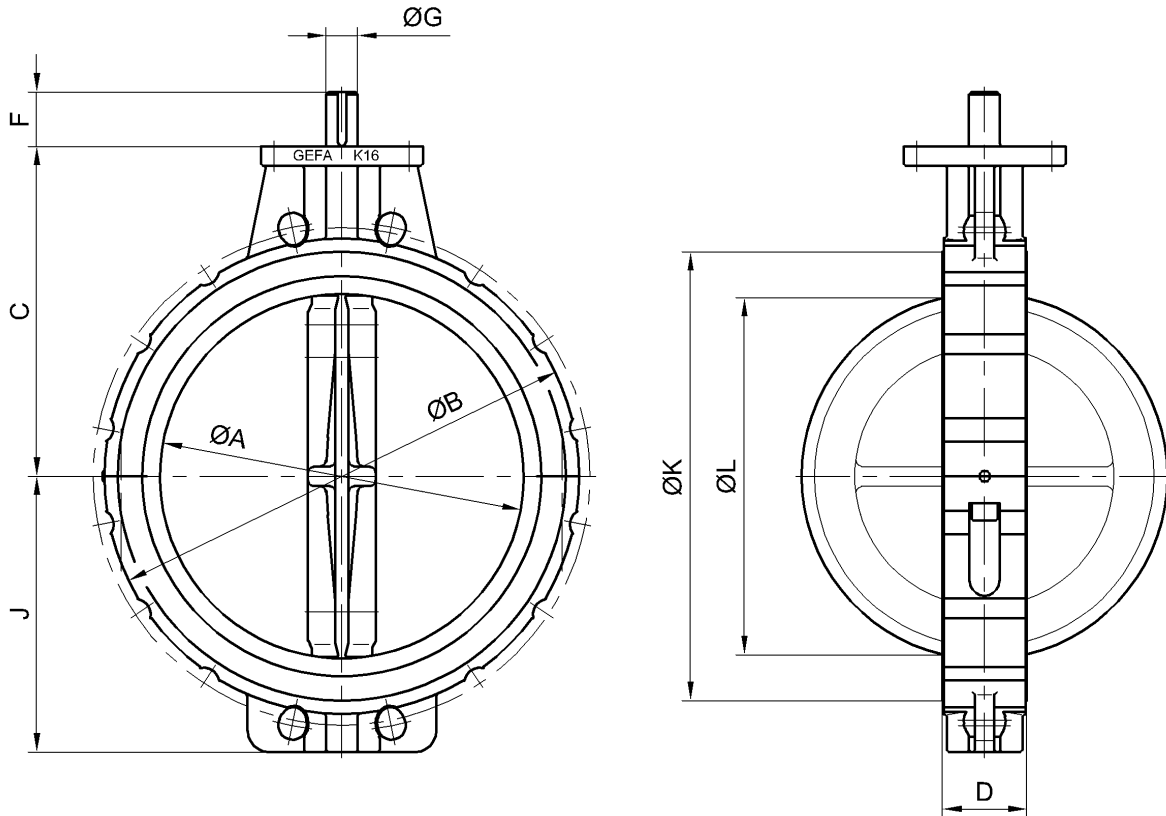

ØK = Sitzring-Außendurchmesser  
 Seat outside diameter

ØL = kleinster Flanschsinnendurchmesser  
 smallest inside diameter of flange

DN	NPS	ØA	ØB	C	D	ØE	F	ØG	J	ØK	ØL	Passfeder Key DIN 6885	Kopfflansch Mounting plate			kg
													ØM	ØN	ISO 5211	
350	14"	337	440	305	78	150	50	29	255	415	330	8 x 7	125	4 x Ø13	F12	47
400	16"	387	485	330	102	150	60	40	285	469	377	12 x 8	125	4 x Ø13	F12	61
500	20"	490	600	403	127	203	60	50	352	571	475	14 x 9	165	4 x Ø22	F16	113

Änderungen vorbehalten  
 subject to changes